

Case Study: Computer Graphics in Automotive Design

This case study investigates how three-dimensional images are rendered effectively in two dimensions. This type of operation is very important in automotive design, for it allows engineers to experiment with images on a computer screen instead of using a three-dimensional model of the automobile. One way to render a three-dimensional image in two dimensions is called a **perspective projection**, which is studied in this case study. You should read Section 2.7 before attempting this case study.

The data for this case study was derived from measurements made on the author's 1983 Toyota Corolla; all coordinates are measured in feet. The origin is placed at the center of the car.

Data Points: $(-6.5, -2, -2.5)$, $(-6.5, -2, 2.5)$, $(-6.5, .5, 2.5)$, $(-6.5, .5, -2.5)$,
 $(-2.5, .5, -2.5)$, $(-2.5, .5, 2.5)$, $(-.75, 2, -2.5)$, $(-.75, 2, 2.5)$,
 $(3.25, 2, -2.5)$, $(3.25, 2, 2.5)$, $(4.5, .5, -2.5)$, $(4.5, .5, 2.5)$,
 $(6.5, .5, -2.5)$, $(6.5, .5, 2.5)$, $(6.5, -2, 2.5)$, $(6.5, -2, -2.5)$

These data points are collected in a data matrix D : each column contains the x , y , and z coordinates of a particular data point. A fourth row containing all ones is attached to the matrix since homogeneous coordinates are being used.

$$\begin{bmatrix} -6.5 & -6.5 & -6.5 & -6.5 & -2.5 & -2.5 & -.75 & -.75 & 3.25 & 3.25 & 4.5 & 4.5 & 6.5 & 6.5 & 6.5 & 6.5 \\ -2 & -2 & .5 & .5 & .5 & .5 & 2 & 2 & 2 & 2 & .5 & .5 & .5 & .5 & -2 & -2 \\ -2.5 & 2.5 & 2.5 & -2.5 & -2.5 & 2.5 & -2.5 & 2.5 & -2.5 & 2.5 & -2.5 & 2.5 & -2.5 & 2.5 & 2.5 & -2.5 \\ 1 & 1 & 1 & 1 & 1 & 1 & 1 & 1 & 1 & 1 & 1 & 1 & 1 & 1 & 1 & 1 \end{bmatrix}$$

This data matrix D accompanies this case study. In addition to the data points, how these data points are to be connected must be known. A table listing which points connect to which others may be supplied. Another way to record which points connect to which others is to use an **adjacency matrix**. This matrix consists only of 0's and 1's; the (i, j) entry in the matrix is a 1 if points i and j are connected. Figure 1 shows both the table of connections and the adjacency matrix.

Connecting the data points as given in Figure 1, results in the picture in Figure 2, which *Mathematica* has rendered as a two-dimensional image.

How has *Mathematica* rendered the picture in Figure 2? The key is a **perspective projection**. A form of this projection is studied in the text on pages 163 and 164. In order to perform a perspective projection a **center of projection** (b, c, d) and a **viewing plane** must be identified. The center of projection is the position of the viewer's eye; the viewing plane is the plane onto which the image is projected. In the book, it is assumed that the center of projection has coordinates $(0, 0, d)$ and that the viewing plane is the xy plane. In what follows it is also assumed that the viewing plane is the xy plane, but any choice of center of projection (b, c, d) will be allowed.

Given the center of projection (b, c, d) and some data point (x, y, z) , the point $(x^*, y^*, 0)$ in the xy plane which lies on the same line as (b, c, d) and (x, y, z) must be found; see Figure 6 on page 163

Point	Coordinates	Connects to
1	(-6.5, -2, -2.5)	2,4,16
2	(-6.5, -2, 2.5)	1,3,15
3	(-6.5, .5, 2.5)	2,4,6
4	(-6.5, .5, -2.5)	1,3,5
5	(-2.5, .5, -2.5)	4,6,7
6	(-2.5, .5, 2.5)	3,5,8
7	(-.75, 2, -2.5)	5,8,9
8	(-.75, 2, 2.5)	6,7,10
9	(3.25, 2, -2.5)	7,10,11
10	(3.25, 2, 2.5)	8,9,12
11	(4.5, .5, -2.5)	9,12,13
12	(4.5, .5, 2.5)	10,11,14
13	(6.5, .5, -2.5)	11,14,16
14	(6.5, .5, 2.5)	12,13,15
15	(6.5, -2, 2.5)	2,14,16
16	(6.5, -2, -2.5)	1,13,15

0	1	0	1	0	0	0	0	0	0	0	0	0	0	0	1	
1	0	1	0	0	0	0	0	0	0	0	0	0	0	0	1	0
0	1	0	1	0	1	0	0	0	0	0	0	0	0	0	0	0
1	0	1	0	1	0	0	0	0	0	0	0	0	0	0	0	0
0	0	0	1	0	1	1	0	0	0	0	0	0	0	0	0	0
0	0	1	0	1	0	0	1	0	0	0	0	0	0	0	0	0
0	0	0	0	1	0	0	1	1	0	0	0	0	0	0	0	0
0	0	0	0	0	0	1	0	0	1	1	0	0	0	0	0	0
0	0	0	0	0	0	0	1	1	0	0	1	0	0	0	0	0
0	0	0	0	0	0	0	0	1	0	0	1	1	0	0	0	0
0	0	0	0	0	0	0	0	0	1	1	0	0	1	0	0	0
0	0	0	0	0	0	0	0	0	0	1	0	0	1	0	1	0
0	1	0	0	0	0	0	0	0	0	0	0	0	0	1	0	1
1	0	0	0	0	0	0	0	0	0	0	0	0	1	0	1	0

Figure 1: Connection of Data Points: Table and Adjacency Matrix

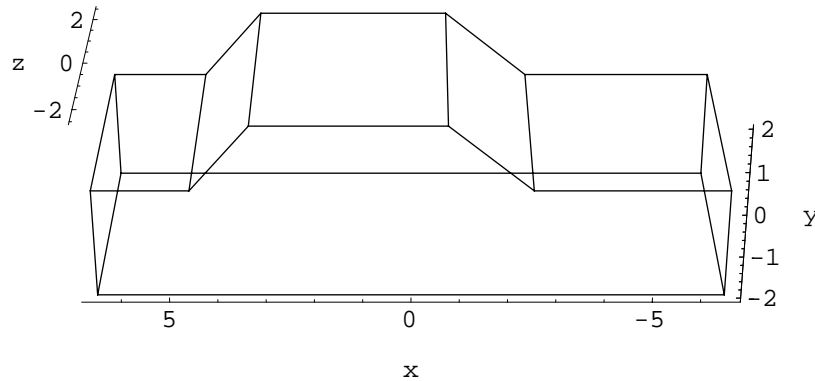

Figure 2: The Toyota data points connected

for a picture. The point (x^*, y^*) in two-dimensional space is then plotted. To find the coordinates x^* and y^* , the equation of the line through (b, c, d) and (x, y, z) must be calculated. As is done on pages 52 and 53 of the text, let the vectors \mathbf{p} and \mathbf{v} be defined as follows:

$$\mathbf{p} = \begin{bmatrix} b \\ c \\ d \end{bmatrix} \quad \text{and} \quad \mathbf{v} = \begin{bmatrix} x \\ y \\ z \end{bmatrix} - \begin{bmatrix} b \\ c \\ d \end{bmatrix} = \begin{bmatrix} x - b \\ y - c \\ z - d \end{bmatrix}$$

The line through \mathbf{p} parallel to \mathbf{v} is needed. Its equation may be written as

$$\mathbf{x} = \mathbf{p} + t\mathbf{v} = \begin{bmatrix} b \\ c \\ d \end{bmatrix} + t \begin{bmatrix} x - b \\ y - c \\ z - d \end{bmatrix} = \begin{bmatrix} b + t(x - b) \\ c + t(y - c) \\ d + t(z - d) \end{bmatrix}$$

where $\mathbf{x} = \begin{bmatrix} x \\ y \\ z \end{bmatrix}$ is a point on the line and t is a parameter which varies over all real numbers.

Since $z = 0$, $d + t(z - d) = 0$, or $t = \frac{d}{d - z}$. The values x^* and y^* may be found by plugging this value of t into their respective equations:

$$x^* = b + t(x - b) = b + \frac{d(x - b)}{d - z} = \frac{dx - bz}{d - z} \text{ and } y^* = c + t(y - c) = b + \frac{d(y - c)}{d - z} = \frac{dy - cz}{d - z}$$

Dividing the numerators and denominators of these fractions by d ,

$$x^* = \frac{x - \frac{b}{d}z}{1 - \frac{1}{d}z} \text{ and } y^* = \frac{y - \frac{c}{d}z}{1 - \frac{1}{d}z}$$

As in the text, the perspective projection will be represented by a matrix P , and homogeneous coordinates will be used to represent the points. The point $(x, y, z, 1)$ must map to the point $(x^*, y^*, 0, 1)$, but these coordinates may be scaled by the factor $1 - \frac{1}{d}z$, and instead map the point $(x, y, z, 1)$ to the point $(x - \frac{b}{d}z, y - \frac{c}{d}z, 0, 1 - \frac{1}{d}z)$. Now it is relatively easy to display P :

$$P \begin{bmatrix} x \\ y \\ z \\ 1 \end{bmatrix} = \begin{bmatrix} 1 & 0 & -\frac{b}{d} & 0 \\ 0 & 1 & -\frac{c}{d} & 0 \\ 0 & 0 & 0 & 0 \\ 0 & 0 & -\frac{1}{d} & 1 \end{bmatrix} \begin{bmatrix} x \\ y \\ z \\ 1 \end{bmatrix} = \begin{bmatrix} x - \frac{b}{d}z \\ y - \frac{c}{d}z \\ 0 \\ 1 - \frac{1}{d}z \end{bmatrix}$$

For example, here is the perspective projection of the Toyota from two different points:

Example 1: $(b, c, d) = (0, 0, 10)$ This is the situation computed in the text. Then

$$P = \begin{bmatrix} 1 & 0 & 0 & 0 \\ 0 & 1 & 0 & 0 \\ 0 & 0 & 0 & 0 \\ 0 & 0 & -\frac{1}{10} & 1 \end{bmatrix}$$

so the data matrix D is converted to PD :

$$\begin{bmatrix} -6.5 & -6.5 & -6.5 & -6.5 & -2.5 & -2.5 & -.75 & -.75 & 3.25 & 3.25 & 4.5 & 4.5 & 6.5 & 6.5 & 6.5 & 6.5 \\ -2 & -2 & .5 & .5 & .5 & .5 & 2 & 2 & 2 & 2 & .5 & .5 & .5 & .5 & -2 & -2 \\ 0 & 0 & 0 & 0 & 0 & 0 & 0 & 0 & 0 & 0 & 0 & 0 & 0 & 0 & 0 & 0 \\ 1.25 & .75 & .75 & 1.25 & 1.25 & .75 & 1.25 & .75 & 1.25 & .75 & 1.25 & .75 & 1.25 & .75 & .75 & 1.25 \end{bmatrix}$$

To obtain coordinates in \mathbb{R}^2 divide the top three entries in each column by the corresponding entry in the fourth row, then discard the third and fourth rows:

$$\begin{bmatrix} -5.2 & -8.67 & -8.67 & -5.2 & -2 & -3.33 & -.6 & -1 & 2.6 & 4.33 & 3.6 & 6 & 5.2 & 8.67 & 8.67 & 5.2 \\ -1.6 & -2.67 & .67 & .4 & .4 & .67 & 1.6 & 2.67 & 1.6 & 2.67 & .4 & 0.67 & .4 & 0.67 & -2.67 & -1.6 \end{bmatrix}$$

One can then plot the points (x^*, y^*) given in the columns of this matrix and connect them using the connection data in Figure 1. The picture in Figure 3 results.

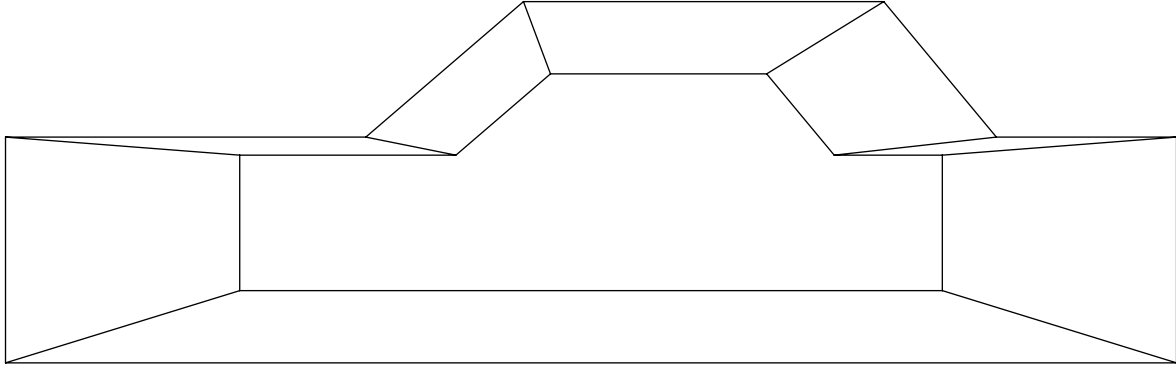

Figure 3: The Toyota from point $(0, 0, 10)$

Example 2: $(b, c, d) = (10, 5, 10)$ In this case

$$P = \begin{bmatrix} 1 & 0 & -1 & 0 \\ 0 & 1 & -\frac{1}{2} & 0 \\ 0 & 0 & 0 & 0 \\ 0 & 0 & -\frac{1}{10} & 1 \end{bmatrix}$$

so the data matrix D is converted to PD :

$$\begin{bmatrix} -4 & -9 & -9 & -4 & 0 & -5 & 1.75 & -3.25 & 5.75 & .75 & 7 & 2 & 9 & 4 & 4 & 9 \\ -7.5 & -3.25 & -7.5 & 1.75 & 1.75 & -7.5 & 3.25 & .75 & 3.25 & .75 & 1.75 & -.75 & 1.75 & -.75 & -3.25 & -.75 \\ 0 & 0 & 0 & 0 & 0 & 0 & 0 & 0 & 0 & 0 & 0 & 0 & 0 & 0 & 0 & 0 \\ 1.25 & .75 & .75 & 1.25 & 1.25 & .75 & 1.25 & .75 & 1.25 & .75 & 1.25 & .75 & 1.25 & .75 & .75 & 1.25 \end{bmatrix}$$

After rescaling by the elements in the fourth row, the \mathbb{R}^2 coordinates are:

$$\begin{bmatrix} -3.2 & -12 & -12 & -3.2 & 0 & -6.67 & 1.4 & -4.33 & 4.6 & 1 & 5.6 & 2.67 & 7.2 & 5.33 & 5.33 & 7.2 \\ -.6 & -4.33 & -1 & 1.4 & 1.4 & -1 & 2.6 & 1 & 2.6 & 1 & 1.4 & -1 & 1.4 & -1 & -4.33 & -0.6 \end{bmatrix}$$

Again plotting the points (x^*, y^*) in this matrix and connecting them using the connection data in Figure 1, the picture in Figure 4 results.

To give the effect of moving around while viewing the Toyota, a sequence of pictures from a varying set of centers of projection could be constructed. Alternatively, a rotation or a “zooming in” on the original data could be done first, then a perspective projection from a fixed point could be performed. Examples of each of these operations follow.

Rotations: To rotate the three-dimensional object about the y -axis by an angle φ , the following calculations are done. By convention, a positive angle is the counterclockwise direction when looking toward the origin from the positive half of the axis of rotation. As in the text, it may be shown that the rotation matrix using homogeneous coordinates for such a rotation is

$$A_y = \begin{bmatrix} \cos \varphi & 0 & \sin \varphi & 0 \\ 0 & 1 & 0 & 0 \\ -\sin \varphi & 0 & \cos \varphi & 0 \\ 0 & 0 & 0 & 1 \end{bmatrix}$$

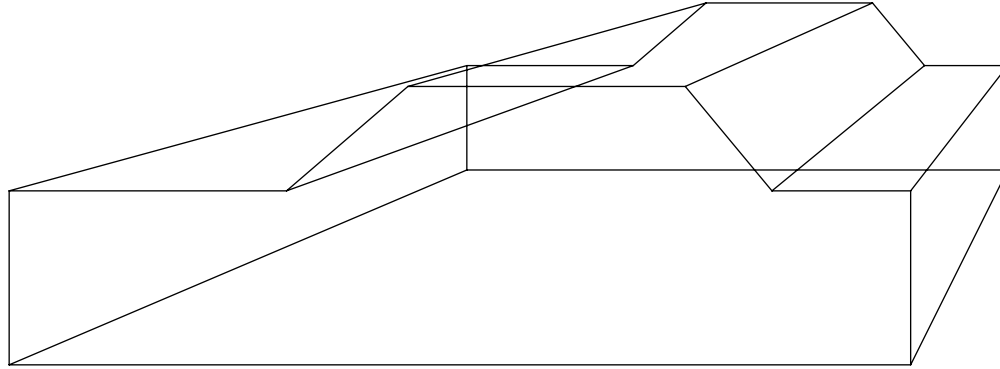

Figure 4: The Toyota from point (10, 5, 10)

Likewise the matrices using homogeneous coordinates for rotations about the x and z axes are

$$A_x = \begin{bmatrix} 1 & 0 & 0 & 0 \\ 0 & \cos \varphi & -\sin \varphi & 0 \\ 0 & \sin \varphi & \cos \varphi & 0 \\ 0 & 0 & 0 & 1 \end{bmatrix} \quad \text{and} \quad A_z = \begin{bmatrix} \cos \varphi & -\sin \varphi & 0 & 0 \\ \sin \varphi & \cos \varphi & 0 & 0 \\ 0 & 0 & 1 & 0 \\ 0 & 0 & 0 & 1 \end{bmatrix}$$

To rotate the Toyota by 45° (or $\frac{\pi}{4}$ radians) about the x -axis one would use the matrix

$$A_x = \begin{bmatrix} 1 & 0 & 0 & 0 \\ 0 & \frac{\sqrt{2}}{2} & -\frac{\sqrt{2}}{2} & 0 \\ 0 & \frac{\sqrt{2}}{2} & \frac{\sqrt{2}}{2} & 0 \\ 0 & 0 & 0 & 1 \end{bmatrix}$$

and apply this matrix to the data matrix D , getting $A_x D$:

$$\begin{bmatrix} -6.5 & -6.5 & -6.5 & -6.5 & -2.5 & -2.5 & -7.5 & -7.5 & 3.25 & 3.25 & 4.5 & 4.5 & 6.5 & 6.5 & 6.5 & 6.5 \\ .35 & -3.18 & -1.41 & 2.12 & 2.12 & -1.41 & 3.18 & -3.35 & 3.18 & -3.35 & 2.12 & -1.41 & 2.12 & -1.41 & -3.18 & .35 \\ -3.18 & .35 & 2.12 & -1.41 & -1.41 & 2.12 & -3.35 & 3.18 & -3.35 & 3.18 & -1.41 & 2.12 & -1.41 & 2.12 & .35 & -3.18 \\ 1 & 1 & 1 & 1 & 1 & 1 & 1 & 1 & 1 & 1 & 1 & 1 & 1 & 1 & 1 & 1 \end{bmatrix}$$

A perspective projection is now applied to this set of data. If the center of projection is $(0, 0, 10)$ as in the first example, $PA_x D$ may be computed, then divided by the fourth row to get the matrix

$$\begin{bmatrix} -4.93 & -6.74 & -8.25 & -5.69 & -2.19 & -3.17 & -.72 & -1.1 & 3.14 & 4.77 & 3.94 & 5.71 & 5.69 & 8.25 & 6.74 & 4.93 \\ .27 & -3.3 & -1.79 & 1.86 & 1.86 & -1.79 & 3.07 & -.52 & 3.07 & -.52 & 1.86 & -1.79 & 1.86 & -1.79 & -3.3 & .27 \end{bmatrix}$$

The points are plotted to get the picture in Figure 5; notice how the image is rotated from that in Figure 1.

“Zooming”: Imaging software packages offer the ability to zoom in (or out) from a picture. Usually 100% zoom indicates the original size of the graphics image. A zoom percentage of 200% would be double that of the original, while a percentage of 50% would be half the size of the original. To make this into a transformation, note that this is a special case of scaling where each of the x , y

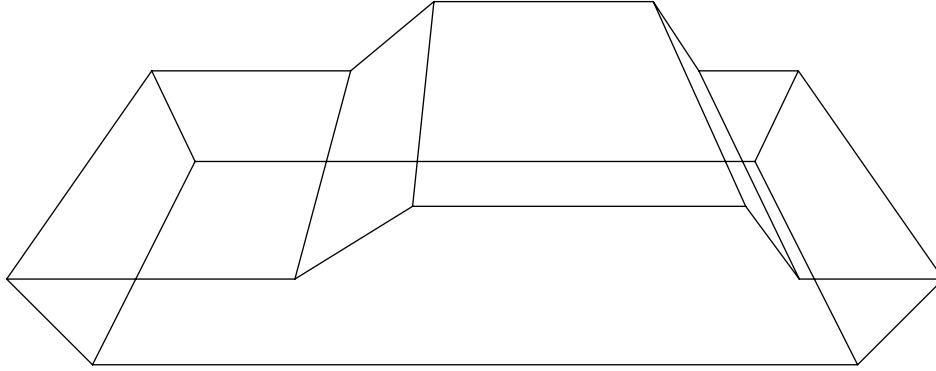

Figure 5: The rotated Toyota

and z axes is scaled by the same factor p . For a 200% zoom, $p = 2$; for a 50% zoom, $p = .5$. As is shown on page 160, the matrix which performs this scaling in homogeneous coordinates is

$$A = \begin{bmatrix} p & 0 & 0 & 0 \\ 0 & p & 0 & 0 \\ 0 & 0 & p & 0 \\ 0 & 0 & 0 & 1 \end{bmatrix}$$

Thus, for example, to zoom in by 200% on the image of the Toyota, one could first find that

$$A = \begin{bmatrix} 2 & 0 & 0 & 0 \\ 0 & 2 & 0 & 0 \\ 0 & 0 & 2 & 0 \\ 0 & 0 & 0 & 1 \end{bmatrix}$$

and thus that AD is the matrix

$$\begin{bmatrix} -13 & -13 & -13 & -13 & -5 & -5 & -1.5 & -1.5 & 6.5 & 6.5 & 9 & 9 & 13 & 13 & 13 & 13 \\ -4 & -4 & 1 & 1 & 1 & 1 & 4 & 4 & 4 & 4 & 1 & 1 & 1 & 1 & -4 & -4 \\ -5 & 5 & 5 & -5 & -5 & 5 & -5 & 5 & -5 & 5 & -5 & 5 & -5 & 5 & 5 & -5 \\ 1 & 1 & 1 & 1 & 1 & 1 & 1 & 1 & 1 & 1 & 1 & 1 & 1 & 1 & 1 & 1 \end{bmatrix}$$

The matrix PAD (given center of projection $(0, 0, 10)$) may now be computed, then divided by its fourth row to get the matrix

$$\begin{bmatrix} -8.67 & -26 & -26 & -8.67 & -3.33 & -10 & -1 & -3 & 4.33 & 13 & 6 & 18 & 8.67 & 26 & 26 & 8.67 \\ -2.67 & -8 & 2 & .67 & .67 & 2 & 2.67 & 8 & 2.67 & 8 & .67 & 2 & .67 & 2 & -8 & -2.67 \end{bmatrix}$$

When these points are plotted, the picture in Figure 6 results. Compare this to the original picture, which is Figure 3. Notice that the size of the zoomed image is not exactly twice that of the original; this has happened because each image is viewed from the same point, and near objects are “magnified” more by the perspective transformation. For the zoomed image to be exactly twice the size of the original, the scaling transformation could be applied **after** the perspective projection. Of course, this will seem to change the center of projection of the zoomed image.

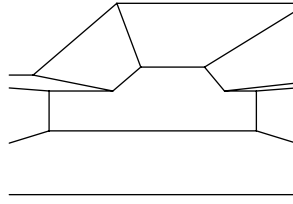

Figure 6: The Toyota: zoom of 200%

Questions:

1. Find the perspective projection using the Toyota data in matrix D using the following points as centers of projection. Sketch (or have your technology sketch) the result.
 - a) $(b, c, d) = (-5, 10, 10)$
 - b) $(b, c, d) = (0, 10, 25)$
2. Rotate the Toyota 30° about the y -axis, then perform the perspective projection with center of projection $(0, 10, 25)$. Sketch (or have your technology sketch) the result. How does this sketch compare with that in Question 1b?
3. Rotate the Toyota 45° about the z -axis, then perform the perspective projection with center of projection $(0, 10, 25)$. Sketch (or have your technology sketch) the result. How does this sketch compare with that in Question 1b?
4. Zoom in on the Toyota with a zoom factor of 150%, then perform the perspective projection with center of projection $(0, 10, 25)$. Sketch (or have your technology sketch) the result. How does this sketch compare with that in Question 1b?

References:

1. Foley, James D., Andries van Dam, Steven K. Feiner, and John F. Hughes. *Computer Graphics: Principles and Practice*. Second Edition. Reading: Addison-Wesley, 1996.
Chapters 5 and 6 contain a wealth of information about transformations and viewing in two and three dimensions.